

The Desktop 3D is a 6 degrees-of-freedom haptic device with active translations, specifically designed to interact in Virtual Reality environments. Its workspace and small footprint address it to an individual use, in front of a desktop screen, a HMD or inside a simulator.



Industrial training

Medical teleoperation

Medical training & simulation

Virtual Reality

3 ACTIVE TRANSLATIONS – 3 PASSIVE ROTATIONS

- ✓ Passive weight balancing
- ✓ Ethernet/UDP communication system
- ✓ Easily removed handle: standard M6 connector
- ✓ Software interface:
 - ✓ Dedicated plug-ins for: 3DEXperience™, Catia™ & Delmia™ V5, Solidworks™
 - ✓ Drivers (binary and/or source code) available for: Python™ for IPSI™, ROS™, ROS2™, CHAI3D™, ODE™, Matlab Simulink™, LabVIEW™
 - ✓ By Partner: Unity3D™ by LS Group, TOIA™ by Generic Robotics

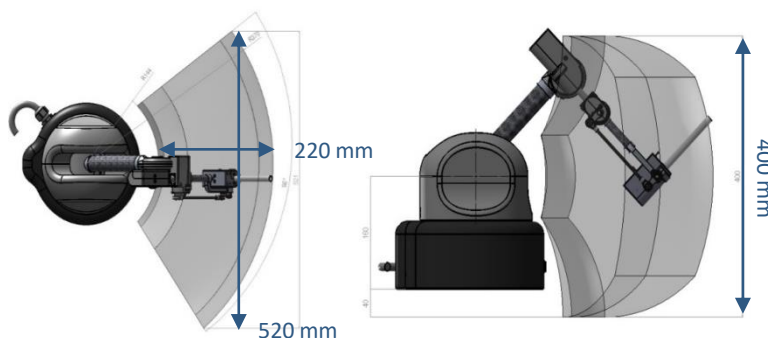

MODULARITY

The user takes hold of the haptic device using a gripper or handle placed at the tip (called “end-effector”).

The end-effector uses a M6 standard connector.

It is easy to remove and replace, so that a frequent change of tool is possible, in order to customize the application and reinforce the sensation of immersion. The gripping tool is equipped with, one push-button dedicated to the offset function.



TECHNICAL

Translation workspace	520 x 220 x 400 mm
Rotation Workspace	260° x 105° x 360°
Payload (center of the workspace):	10 N (peak)/ 3 N (continuous)
Position resolution	0.023 mm
Rotation resolution	0.35 °
Device Weight	3.6 kg

ELECTRICAL

Power supply	100-240 VAC 50/60Hz single phase
Consumption	Less than 200W

SOFTWARE

Maximum translation stiffness	1000 N/m
Update Rate	1000 Hz

The Desktop 3D and Desktop 6D are also available upside-down. We are available to discuss with you any specific request for integration.

HAPTION S.A.

8 ZA Route de Laval – 53210 SOULGE SUR OUETTE – France
 Tel. +33(0)2 43 64 51 20 Fax. +33(0)2 43 64 51 21
 Email : contact@haption.com <https://www.haption.com>