



VIRTUOSE 6D TAO™

The Virtuose 6D TAO is a 6 active degrees-of-freedom haptic device with a passive analog finger gripper acting as a 7th DOF.

Thanks to its large workspace, interaction capacities and Ethernet or EtherCAT interface, it fit perfectly the industrial applications.

It is designed to easily control a remote robot with small payload (6kg max):

Nuclear Teleoperation # Industrial Teleoperation



6 ACTIVE DEGREES-OF-FREEDOM, WITH PASSIVE FINGER GRIPPER

- ✓ Passive weight balancing
- ✓ Ethernet UDP communication system, or EtherCAT on request.
- ✓ Ergonomic telerobotic handle (end effector) designed for convenient and intuitive remote manipulation of your robot
- ✓ Button box on the forearm that extends the operator's actions without having to let go of the handle
- ✓ Reduced weight, allowing transportation without specific equipment
 - ✓ Plug & play with Haption TREX teleRobotics Extender, generic controller compatible with many leading robot brands
 - ✓ Long term native drivers (binary) in C++ and C. Drivers availables for ROS2™, ROS™, CHAID3D™ open source platforms.
 - ✓ Can be used* with open source platforms (Godot™, Bullet™, SOFA™, ...) and with third parties platforms (UnReal™, Unity™, NVIDIA Flex™, LabVIEW™, Matlab™/Simulink™, TAO2000™, CORTEX™, XDE™...). (*No drivers/examples are supplied.)
 - ✓ Industrial solutions with third party solutions such as Unity™, UnReal™ by our Partners : LS Group, Tree-C, TOIA Ltd, ...

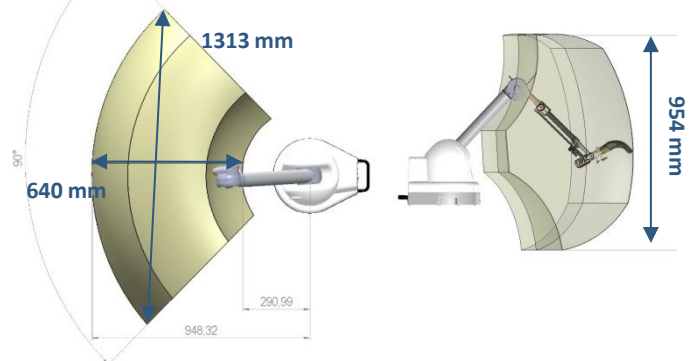

TECHNICAL

Translation workspace	1313 x 640 x 954 mm
Rotation Workspace	320° x 110° x 257°
Payload (center of the workspace):	35 N (peak)/ 10 N (continuous)
Rotation force: Peak, Continuous	3,3 Nm , 1 Nm
Position resolution	0.0164 mm
Rotation resolution	0.003 °
Device weight	17 kg (+ external power supply 3,4kg)

ELECTRICAL

Power supply	100-240 VAC 50/60Hz single phase
Consumption	Average consumption 200W Max consumption: 800W

SOFTWARE

Maximum translation stiffness	2 000 N/m
Maximum rotation stiffness	40 Nm/rad
Update Rate	1 000 Hz

PRACTICAL AND VERSATILE

The ergonomic telerobotic handle (end effector) is equipped with 4 user buttons, one can be used to implement a shift feature to extend the workspace, 1 LED indicator, and an analog finger trigger provides a signal 0 – 100%, is acting as a 7th DOF for instance to control a gripper on the robot.

An additional user button box on the forearm extends the operator's actions without having to let go of the handle, it provides several user buttons, selectors and a LED indicator.

All user push-buttons status & LED controls are available in the native software interface.

The end-effector is easy to remove and replace, with no tool, in order to customize and enhance the control for your application.

We are available to discuss with you any customized needs you have.



Information in this document is subject to change without notice.

HAPTION S.A.S.

8 ZA Route de Laval – 53210 SOULGE SUR OUETTE – France

Tel. +33(0)2 43 64 51 20

Email : contact@haption.com <https://www.haption.com>

